

Heavy Duty Electronic Crane Scales

FEATURES:

- Heavy Duty Aluminum Enclosure
- LED Display 38mm with Backlight
- Water-Proof Panel Buttons
- American Standard shackle and 360 Degrees Swivel Hook
- Units Conversion, Hold, TARE, Zero, Total Accumulation, Calibration,
- Auto Zero, Auto Power off, anti-motion, illumination level, Gross & Net weight
- AC/DC with Dual Changeable External Charging Battery System to insure Continues Operation
- Over Load Protection with Alarm
- Remote Control Calibration
- High-quality Alloy Steel load Receptor
- Rechargeable Battery (6 V/10Ah) & Easy to Replace Battery Pack
- Extended Warranty 3 Years



SPECIFICATIONS:

SENS CS-C	Model Info.
Display	38mm LED display
Face-Board	Water-Proof Panel with 5 keypad
Functions	Tare In/Tare Out, Hold low Voltage Alarm, Overload Alarm, Digital Calibration, Tare Set, Total/Delete/Clear Total, View Total, Auto Off Set, Power-Saving Mode, Display Luminance Set, Display Speed Set, Anti-motion Set, Gravity Acceleration Set
Accuracy Class	OIML III Standard
Tare Range	100% F. S. (Full Scale)
Zero Range	4% F. S.
Safe Overload	120% F. S.
Ultimate Overload	400% F. S.
Overload Alarm	100% F. S. +9e
Battery	6V/10Ah, Life 100 hour
Temperature Range	-10°C ~ +40°C

Accessories



Remote Control

Battery

Adapter

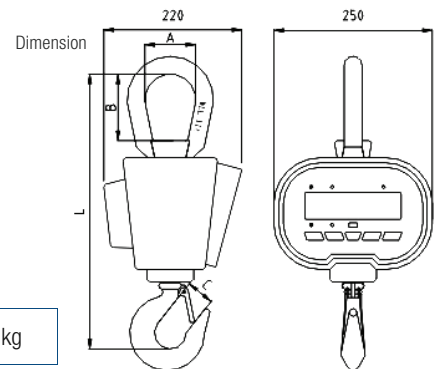

Capacity & Division	1 ton / 0.5 kg	2 ton / 1 kg	3 ton / 1 kg	5 ton / 2 kg

